

STEP-BY-STEP GUIDE

Improving Efficiency in Municipal Street and Public Space Lighting



INTRODUCTION

Street lighting is an important part of a municipality's nighttime landscape—lighting can be used to enhance public safety and security while improving the aesthetic appeal of the surrounding properties. However, street lighting represents a large electrical load and can be one of the highest costs for a municipality. By eliminating unnecessary street lighting and converting older lighting technologies to light-emitting diodes (LEDs), municipalities have the opportunity to reduce the cost of outdoor lighting while enhancing the nighttime environment.

This guide provides Vermont municipalities with a step-by-step process for improving the efficiency of street and public space lighting, and upgrading to LED technology. By converting to LED lighting, municipalities can realize the following benefits:

Reduced energy use: LEDs can reduce energy use by 50-80% compared to existing street lighting.

Reduced energy costs: Vermont's electric utilities offer LED street light lease rates that are lower than rates for conventional street light technologies.

Reduced light pollution and wasted light: LEDs are designed to be highly directional, and can be designed to provide light only where it is needed (such as streets and sidewalks) and reduce the amount of light where it is not needed (such as the night sky and neighboring properties).

Improved light quality: High-quality LED fixtures improve visibility through better color rendering and uniform illumination patterns.

In addition to the benefits provided by LEDs, municipalities can reduce energy costs and light pollution by properly sizing and/or removing existing street lighting that may not be serving its intended purpose, while ensuring that community lighting needs are met. Removing unnecessary street lights also results in a reduction in municipal electric bills.

The following topics are covered in this guide:

- LED Street Lighting Basics
- Getting Started in Your Municipality
- Opportunities for Removing Unnecessary Street Lighting
- Determining Ownership of Fixtures
- Installing LED Replacement Lighting

LED STREET LIGHTING BASICS

LED lighting technology offers a radical departure from traditional lighting technologies. Exterior lighting has been historically provided by singular, high-output light sources. In contrast, LED lighting systems are based on clusters of individual LED lights grouped into modules which operate as a unified system. Unlike other lighting technologies, LEDs are inherently directional, which improves efficiency by directing all of the light out from the fixture without having to rely on a reflector. In all other lighting technologies, a significant percentage of the light produced by the bulb is often trapped within the light fixture housing. LED light can be directed precisely where it is needed, thereby eliminating wasted light and its associated cost. When directional properties are accounted for, LEDs can provide a more even illumination pattern delivered to the area being lighted with less overall light. An LED fixture with lower wattage and light output can effectively match

the performance of a higher-wattage, single-lamp fixture using traditional technology. Typically, LED lighting can save between 50-80% of electricity use compared to existing equipment, depending on the specific application.

LED street lights provide more uniform illumination with less wasted light.

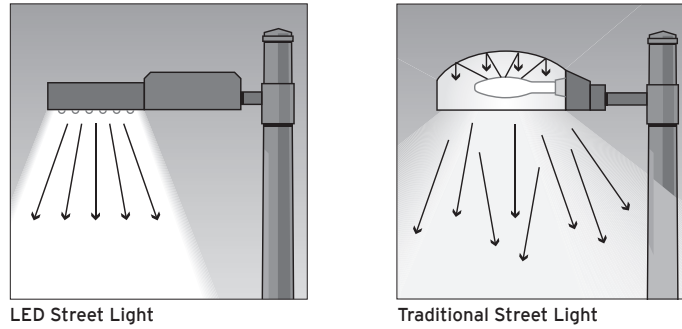

LED fixtures are more efficient, offer better color rendition, and last longer compared to older technologies, as summarized in Table 1 below.

TABLE 1: Comparison of Outdoor Lighting Technologies

Light Fixture Replacement Summary Metric ¹	LED	Metal Halide	High Pressure Sodium	Mercury Vapor
Delivered Efficacy (lumens/watt)	High	Moderate - Low	Moderate	Low
Lifetime	Very long	Medium	Long	Long
Color Rendition	Very good	Good - Very good	Poor	Poor

GETTING STARTED IN YOUR MUNICIPALITY

Obtain a Street Light Inventory and Map

One of the first steps your municipality can take is to obtain an inventory of municipally-leased street light fixtures from your electric utility. Electric utility companies should be able to provide a digitized map to accompany the inventory. This inventory will include a list of your town's lighting, including the fixture ages, types, and wattages. In addition to leased fixtures, be sure to identify any municipally-owned street lights. In many cases, municipally-owned lights may be hand drawn on a town map. You may want to consider translating this information to a GIS-based map by charting data points. If your municipality is large enough, it might have the capacity to perform this service. If not, your regional planning commission should be able to provide this service.

Form a Team

Forming a team of individuals committed to reducing municipal street lighting costs

¹ For comparison purposes only; actual performance can vary widely. Municipalities will need to look at individual situations when replacing lights with LEDs to determine how much can be saved, and how much lighting quality can be improved.

is a critical step. Vermont has more than 130 volunteer town energy committees or energy coordinators which are active in promoting energy efficiency and renewable energy in their communities. Energy committees can play a key role in identifying opportunities for removing unnecessary street lights and developing a plan for converting to LEDs. A group or committee of five to seven people with a diverse range of skills and experience will provide the foundation for a good team. It would be good to have representation from the select board, zoning board, or public works staff as part of your team. Also consider consulting with a member of the police or fire department. For more information about town energy committees, visit www.vecan.net.

Build Support

One of your key steps will be to enlist the support of your local elected leaders, such as selectboard and/or city council members, as well as town citizens. Committees should work in tandem with selectboards throughout the process to help ensure their endorsement of any funding requests. It is critical to build support among elected officials and residents for making energy efficiency improvements before asking for funds.

Ask to be on the agenda of a selectboard meeting to inform them of your interest in reducing municipal lighting energy costs and to solicit their input on how to best proceed. One of your tasks will be to clearly communicate information about the costs and potential savings in a manner that is easy for the public and elected officials to digest. It is worthwhile to spend the necessary time to prepare clear, factual materials about what efficiency improvements will be made, associated energy savings and costs, and the payback period. It is also helpful to use graphics to display the information. Your committee should make the information available through a variety of forums, including setting up a table at town meetings, publishing articles in the local newspaper, sending out e-mail updates, or even holding a public informational meeting. The use of web-based communication avenues could also be effective, including Twitter, Facebook, and Front Porch Forum in some Vermont communities.

OPPORTUNITIES FOR REMOVING UNNECESSARY STREET LIGHTING

Where is Street Lighting Needed?

Many light fixtures were placed in service 20, 30, or even 50 years ago, and might no longer serve their intended purpose. In the past, when energy was relatively inexpensive, municipalities erred on the side of installing more lighting rather than less—meaning many locations may be over-lit. For example, a street light may have been placed near a driveway that previously served a municipal garage, but the garage or driveway may no longer be in use. You may also find disparities between lighting levels in one rural area of town versus another.

Many municipalities are re-evaluating their municipal outdoor lighting needs due to the higher costs of electricity and the value of making a more dark-sky-friendly environment. Your review of municipal lighting may be the first time a comprehensive assessment has been done since current street lighting was installed. Your municipality will want to review all street lighting locations to see if current and projected needs for various areas of your community are being met.

Municipalities generally install street and public lighting for practical reasons, such as safety, outdoor public activities, or increased commerce, and sometimes strictly for aesthetics.

Locations of municipal outdoor lighting include:

PUBLIC SPACES

Outdoor spaces where people are likely to gather, walk, or recreate include:

- recreational areas (tennis, basketball, and volleyball courts, skating rinks, etc.),
- parking lots for municipal buildings (town halls, libraries, schools, etc.),
- downtown street lighting, and
- other locations such as train or bus depots.

ROADWAYS

Roadway lighting is typically utilized in Vermont as an added safety measure for busy transportation corridors and a visual signal that travelers have arrived at key town centers, attractions, or intersections. Roadway lighting is also placed near unusual road conditions such as sharp or blind curves, high-density neighborhoods, roads passing by or through large destination centers, and approach ways to and through town centers.

Identify Criteria for Evaluating Lighting Needs

It will be important to develop criteria for evaluating where light is needed and what levels of light are needed in your community. Some criteria for evaluating where lighting is needed include²:

SECURITY REQUIREMENTS

A common misconception is that providing more light will improve safety and security, and reduce crime. On the contrary, more light can actually reduce safety³ and security by creating glare, reducing the eye's ability to see objects in the periphery, and improving visibility for those that commit crimes.

PEDESTRIAN SAFETY

Well-designed street lighting can help increase visibility of people and objects along the side of the road in areas of high traffic or pedestrian use. Crosswalks are key areas where sufficient lighting is needed.

TRAFFIC SAFETY

Well-designed street lighting can help increase the visibility of vehicles to avoid collisions. In general, there should be sufficient street lighting to signal the location of each intersection of major public roads where there is significant vehicular traffic. Areas where lighting can be valuable for traffic safety include high-traffic streets, high-volume intersections, and dangerous or blind curves.

CONVENIENCE

Street lighting can also be used as a convenience in residential areas, such as illuminating sidewalks at night. In general, there should be street lights sufficient to illuminate sidewalks in residential areas where there are significant numbers of pedestrians.

SUPPORT ECONOMIC DEVELOPMENT AND AESTHETICS

Lighting levels relate directly to the particular application in the community. The Illuminating Engineering Society of North America (IESNA) provides recommendations

² “NYSERDA How-to Guide to Effective Energy Efficient Street Lighting for Municipal Elected/Appointed Officials,” October 2002.

³ “Guideline for Security Lighting for People, Property, and Public Spaces,” IESNA, 2003. www.smsiinc.com/pdfs/security-lighting-guide.pdf

on lighting levels for different applications. Higher light levels may be required for bright, urban environments. A lighting professional can be used to help determine adequate light levels for areas of concern. (See www.encyclopedia.com/streetlighting and Figure 1 below.)

One proposed method for systematically identifying lighting needs and levels is to establish lighting zones. IESNA and the International Dark Sky Association jointly developed a Model Lighting Ordinance that incorporates the concept of lighting zones.⁴ These zones can be focused on categories such as commercial centers, residential areas, recreational areas, pedestrian walkways, and main arteries. These zones provide a starting point for evaluating existing lighting levels and comparing these levels to lighting needs established for a particular zone. (See Figure 1 below.)

FIGURE 1: Sample Lighting Zones, City of Montpelier

Lighting Zone #0: Rural areas. No municipal lighting provided. Zone is rural, agricultural, and undeveloped or sparse with little or no pedestrian activity at night and no sidewalks. Exceptions include hazardous or challenging roadway conditions, such as dangerous intersections, steep hills, or curves. Foot-candle level = 0.05.

Lighting Zone #1: Predominately residential areas. Low level of lighting provided. There is relatively low pedestrian activity at night, with residential areas with sidewalks. The character of the area would not be adversely affected or disturbed by low light levels. Exceptions include pedestrian crossings and hazardous roadway conditions and intersections requiring illumination for safe travel. Estimated 280 foot spacing between fixtures. Foot-candle level = 0.1.

Lighting Zone #2: Multifamily residential and mixed use. Moderate level of lighting provided. This zone covers mixed use and multifamily residential development, home businesses, and some commercial with low to moderate traffic volumes and is characterized by moderate nighttime pedestrian traffic. Sidewalks (or bike lanes) are provided in most of the zone. All crosswalks are marked and intersections are illuminated. Estimated 120-160 foot spacing between fixtures. Foot-candle level = 0.3.

Lighting Zone #3: Commercial areas and high traffic areas. Highest level of lighting provided. Zone is primarily commercial and high traffic areas, including downtown areas and main thoroughfares. Sidewalks are located along most streets, and traffic level is moderate to high. Intersections and crosswalks should be well lit. Lighting should be uniform and continuous. Estimated 60 foot spacing between fixtures. Foot-candle level = 0.8.

⁴ To download a copy of the ordinance and associated user guide, go to: http://docs.darksky.org/MLO/MLO_FINAL_June2011.pdf

Lighting levels can be evaluated in a number of ways:

FIELD MEASUREMENTS

Undertaking field measurements can be an effective way to determine whether lighting can be reduced or eliminated. Light meters are an essential tool for conducting field measurements of lighting levels.⁵ (See spacing chart below and IESNA recommendations at www.encyclopedia.com.) Efficiency Vermont lends light meters to municipalities. To obtain a meter free-of-charge, call 888-921-5990 or e-mail info@efficiencyvermont.com.

GENERAL ESTIMATES

You can develop estimates of foot candle levels based upon a combination of factors, including wattage levels, types of fixtures, height of fixtures, and distance between fixtures. (See Chart 1 below. Note that this chart is for illustrative purposes only. Contract with a lighting design professional to assist in developing specific estimates for your municipality.)

CHART 1: Example Illuminance Versus Spacing for LED Replacements

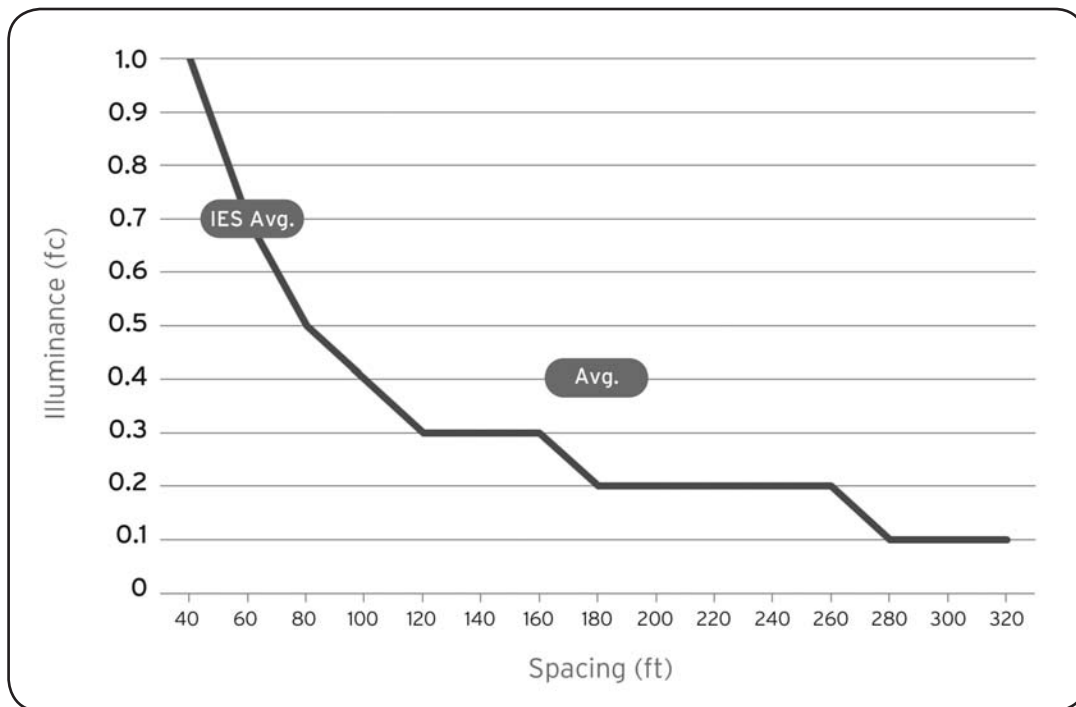

Identify List of Street Lights for Removal

The process for identifying street lights for removal can vary. A recommended process is as follows:

PREPARE STREET LIGHT POLICY

Consider developing a policy that governs the placement of street lights in the community. (See a sample policy from the Town of Jaffney, NH at www.encyclopedia.com/streetlighting).

⁵ Most existing street lighting types, such as mercury vapor and high pressure, degrade over time. Therefore, people are often used to lower lighting levels than new fixtures will provide. Mercury vapor and high pressure sodium fixtures also have a lower CRI (color rendering index—a measure of the quality of color light) compared to LEDs—which results in a poorer quality of light.

REVIEW MAP WITH STREET LIGHT ZONES

Overlay the lighting zone map with the street light fixture map. Based upon these zones, identify potential fixtures that can be eliminated. Be sure to take into consideration the location of fixtures within the lighting zones and the relative spacing between fixtures.

CONDUCT A STREET-BY-STREET ASSESSMENT

With a map in hand, conduct a street-by-street drive- or walk-through of the entire municipality to get a sense of what lighting is in place and to make sure the proposed list of street lights identified for removal is consistent with the criteria. Be sure to look at site-specific lighting to verify the accuracy of what lighting actually exists and the appropriateness of current lighting levels. Some considerations in your drive/walk-through include:

Uniformity: Look at the uniformity (or lack thereof) of lighting within the zone. How far apart are poles with lighting fixtures located? Are there several fixtures within close proximity that might be redundant?

Intersections and cross-walks: Make sure lighting is placed at all crosswalks and intersections.

Exceptions to the rule: Look for unique circumstance that might justify lighting, such as bus stops, steep hills, dangerous curves, historic buildings, trailheads, or monuments.

Opportunities for additional lighting: Identify areas where additional lighting might be needed, such as areas with limited sight distance or under-lit crosswalks.

DEVELOP LIST OF RECOMMENDED LIGHTS TO REMOVE, MOVE, AND/OR ADD

Based on the assessment, prepare a list of potential street lights to remove, along with a list of street lights to add and move. Be sure to map this information as well.

SOLICIT INPUT FROM ELECTED OFFICIALS AND THE PUBLIC

Once you have developed the map and inventory, prepare a memorandum for your selectboard or city council, and ask them for an opportunity to present your findings at one of their regularly-scheduled meetings. Ideally, your committee has kept elected officials apprised of your progress throughout the process. The initial review with elected officials can be considered the first step in your outreach. Other opportunities include:

Placing signs on poles: Consider placing signs on the utility poles of street lights that have been identified for removal. These signs should include information on who to contact if a resident has concerns about the removal of a particular street light and information about the appeal process.

Providing a viewable/downloadable map: Post a map and list of proposed lights for removal for public review on the municipality's website.

Holding a public meeting: Hold a public meeting to discuss the process used and plans to eliminate street lights.

Establishing an appeal process: Provide an opportunity for residents who are concerned about the removal of specific street lights to make an appeal before elected officials.

PREPARE A FINAL LIST OF STREET LIGHTS FOR REMOVAL

Based on input from the public and elected officials, prepare a modified list of street lights for removal and present it to municipal decision makers and gain their approval. You can then provide the list to your utility, and the utility will remove fixtures at the same time it replaces remaining fixtures with LEDs. Several Vermont municipalities have successfully removed a sizable percentage of street light fixtures. (See Table 2 below.)

For more details, including case studies from other towns, see www.encyclopedia.com/streetlighting.

Your committee might also want to consider a trial outage in which you would ask the utility to turn off unwanted lights for a given period of time and seek additional community input. Your committee should be aware that most utilities charge customers to turn off lights, but do not charge for actual removal of fixtures.

Potential liability issues associated with the decision to modify or eliminate lighting may need to be addressed. A professional consultant can help determine the risks that may be associated with a particular street light's removal or reduction.

TABLE 2: Results of Street Light Removal

Town	Initial # of fixtures	Total # of fixtures removed	% of fixtures removed
Hartford	521	175	33%
Rockingham	461	123	27%
Shelburne	233	124	47%
Williston	160	53	33%

DETERMINING OWNERSHIP OF FIXTURES

Most municipalities in Vermont lease a large percentage of their street lighting fixtures from their electric utility. However, municipalities can take ownership of their light fixtures. Your committee can explore the options offered by your utility through the rate tariff. In 2011, most Vermont utilities adopted new tariffs specifically for LED street lights. These tariffs include rates for both municipally-leased and municipally-owned fixtures. The tariffs for LEDs are generally lower than the comparable fixtures they are replacing. For municipally-leased fixtures, the municipality pays a flat monthly fee that includes the cost of the fixture, energy charges, and maintenance. The fee amount is governed by the wattage of the fixture. Alternatively, under municipal ownership, the municipality pays a monthly energy charge and pole-leasing fee, and is responsible for the purchase, installation, and maintenance costs.

Depending on the utility, there can be potential long-term cost savings associated with municipal ownership as opposed to municipal leasing. Municipal ownership requires that the municipality raise the capital and pay for the purchase and installation. A municipally-owned system will require ongoing maintenance for system components that will eventually need replacement, and these costs will be the responsibility of the town.

The cost-effectiveness of pursuing street light ownership varies by utility and should be carefully considered by your municipality. Efficiency Vermont can help by conducting an economic analysis on the relative costs of municipal ownership versus leasing.

INSTALLING LED REPLACEMENT LIGHTING

Municipal Leasing

If your municipality decides to continue leasing its fixtures, follow these simple steps:

Submit lists to utility: Once you have finalized the list of fixtures you would like to remove, provide the list to your utility. The list should correspond with the utility's fixture list, including fixture type, wattage, and pole identification number. At the same time, be sure to provide the list of fixtures you would like to retain and have replaced with LED fixtures. It is possible that your committee will have identified some discrepancies between the utility inventory/map and your list of fixtures based on field assessments. This effort will probably involve an iterative process between the municipality and the utility to reconcile fixture counts and locations.

Identify potential changes in lighting levels: As part of the process of identifying lighting needs, your committee may have identified specific areas where it would like to increase or decrease lighting levels of specific fixtures. These recommendations should be done in conjunction with a lighting professional. When submitting the list of fixtures you want to replace with LEDs to your utility, identify specific fixtures where you want to have the lighting levels adjusted.

Review proposed LED replacement fixtures: Your utility will provide you with a list of proposed replacement fixtures based on the list of fixtures your committee provided. A meeting can then be scheduled with a utility representative to review the list of fixtures for removal, proposed replacement fixtures, and review any discrepancies in the inventory list.

Sign agreement with utility: Once you have agreed on the list of fixtures to remove and replacement fixtures, your utility will ask you to sign a lease agreement that stipulates the terms of the lease. These terms will vary by utility and are stipulated in the utility tariffs. The utility will then issue a work order to remove and install fixtures. How quickly the utility will be able to schedule the work will be influenced by factors such as crew availability, budget, and other projects in the queue.

Municipal Ownership

Municipalities may be able to take over ownership of their street light fixtures. This option can result in more flexibility over what LEDs and controls to install, and potentially greater long-term cost savings, but it also requires time to do the project design, gather the capital investment, and maintain the street lighting system.

Some of the steps involved in municipal ownership include developing a project scope and budget, identifying and securing funding, and purchasing and installing the lights. For more information, please visit www.encyvermont.com/streetlighting.

CONCLUSION

Municipal street and outdoor space lighting offers enormous opportunities for reducing municipal electric bills. This guide is intended as a primer to help Vermont municipalities take the steps necessary to reduce municipal street lighting costs. For more information or guidance, contact Efficiency Vermont at 888-921-5990 or info@encyvermont.com.

ATTACHMENT A: LAMP AND FIXTURE HOUSING TYPES

LAMP TYPES

Identifying lamp types and wattages is critical to determining what replacement LED fixtures will be needed. The most common lamp types in Vermont include:

Metal Halide Lamp: Typically a fairly large lamp with a bulbous shape and a very bright white to bluish light. The color tends to shift over time and it is common to see a row of identical fixtures each emitting a slightly different color.

High-Pressure Sodium Lamp: These lamps are large and similar in shape to metal halides. The distinctive difference with these lamps is the golden yellow light they emit, derived from the sodium gas within.

Mercury Vapor Lamp: The mercury vapor lamp looks very similar in shape to a metal halide. There are fewer of these lamps in service today because of their lower efficiency, and because federal law now bans the sale of new mercury vapor fixtures and components. These lamps emit a more gray-greenish light and have a lower wattage and therefore dimmer appearance. They become dimmer over time rather than fail outright, meaning they may be kept in service beyond their actual usefulness.

For the lamp types listed above, a larger bulb will mean a brighter light output and higher wattage use. Your utility should be able to provide the type and wattage of light fixtures.

FIXTURE HOUSING TYPES



Cobrahead

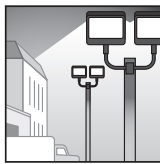

Flood Light

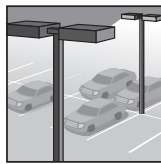

Shoebox

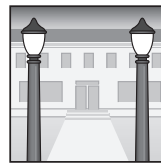

Post-Top

All of the lamp types above are installed in a fixture housing designed to hold the lamp, protect it from the elements, and spread the light in a controlled fashion by using reflectors in the fixture housing.

When attached directly to a utility pole, a “cobrahead” or flood style is generally used. The cobrahead, as the name implies, looks like a metallic head of a snake with a bulb in it, attached to the end of a tubular metal arm. A “flood light” tends to look like a box mounted directly to or close to the utility pole with a much shorter arm and with the light aimed in a general direction. These types of light fixtures tend to spread the light out in a wide arc with little dark-sky control features and can also cause a fair amount of glare. Most utility pole installed fixtures, including cobraheads and flood lights, are leased directly from the utility.

Fixtures are also often installed on dedicated lighting poles. These fixtures can be either very plain and square shaped or decorative, to match the historical character of a community. The plain, square-shaped fixtures are called “shoebox” fixtures, while decorative historical fixtures are generally referred to as “post-top” with a metal and glass diffuser top. These types of installations may or may not be more dark-sky compatible and emit less glare, especially from a distance. Most lights on dedicated light fixture poles are owned and maintained by the associated property owner.

ATTACHMENT B: CASE STUDY: TOWN OF HARTFORD

The town of Hartford, VT, conducted an evaluation of their street lighting in 2010 and solicited bids for replacement of over 300 of their municipal light fixtures.

BACKGROUND

The municipality of Hartford is composed of several villages and districts, including White River Junction, Wilder, Hartford, and Quechee. In an effort to reduce municipal expenses, Town Manager Hunter Rieseberg worked with Highway Superintendent Allyn Ricker and Town Engineer Chuck Wise to evaluate if savings could be generated from reducing the amount of outdoor public lighting.

In April 2010, Green Mountain Power Corporation (GMP) revised their outdoor public lighting tariff which allowed customer-owned fixtures installed on leased poles and also provided for LED leased lighting options as well. Hartford wanted to see if the new tariff was cost-effective for their needs. GMP provided leased lighting for about 85% of the town.

PROCESS

The team conducted an inventory of the municipality's outdoor public lighting and found 860 street lights within Hartford. Originally, 562 of those street lights were paid by the municipality; the remaining were privately installed and funded. After the team's first lighting review, the municipality initially recommended that 207 of those fixtures be removed, 7 more be added in critical locations, and 348 be kept at their present location.

Of the remaining 348 light fixtures, 300 were identified as making economic sense for replacement because they were covered under the new GMP tariff. Next, the Hartford team conducted a technical evaluation to determine which lighting could be replaced with more efficient light fixtures. The municipality hired an engineering firm to help evaluate the new tariff structure, obtain an understanding of what LED products were available, and determine if the option of purchasing new LED-based lighting would be cost effective. The analysis matched products from Efficiency Vermont's LED eligible products list to the existing lighting types to be replaced. The vast majority (80%) of the existing fixtures cited for replacement were 100 watt mercury vapor fixtures, with smaller quantities of 70 watt mercury vapor and 400 watt mercury vapor.

Once manufacturer's bids were received, each one was given the opportunity to present their case, show samples of the proposed fixtures, and verify warranties and life expectancies of the various components. The municipality wanted to know how much of each product was made in the United States, and decided to use simple photo-eye controls for all-night lighting and wanted to ensure controls being used for the LED replacements matched GMP controls to better facilitate future maintenance.

128 Lakeside Avenue, Suite 401
Burlington, Vermont 05401



888-921-5990
www.encyvermont.com